



<b>Document Title</b>	Main Gear Axle Spacer, Evolution
<b>Document Number</b>	016-0019
<b>Date</b>	March 31, 2014

**Subject:** Lancair Evolution Main Gear Axle Spacer Installation

**Affected Aircraft:** All Lancair Evolution Aircraft

**Status:** Service Advisory

**Importance:** Voluntary Compliance

**Background:** On some aircraft the brake rotor on the main landing gear may contact the strut during a hard landing with a heavily loaded aircraft. This Service Advisory defines the procedure for installing a spacer onto each of the main landing gear on the Lancair Evolution. Installation of the spacer is only required if there is a clearance conflict between the brake rotor and the strut. Lancair will provide spacers and cotter pins upon request. If there are any matters herein requiring clarification, please contact Lancair at 541.923.2244.

**Action:** The spacer installation procedure for the right main gear is described below. Spacer installation for the left main gear is similar.

1. Review the entire Service Advisory then list and assemble all needed materials and tools.
2. Support the aircraft with the main tires off the ground. Secure the tail using a tail stand to lift the nose gear off the ground.

3. Remove the brake caliper and brake pads.

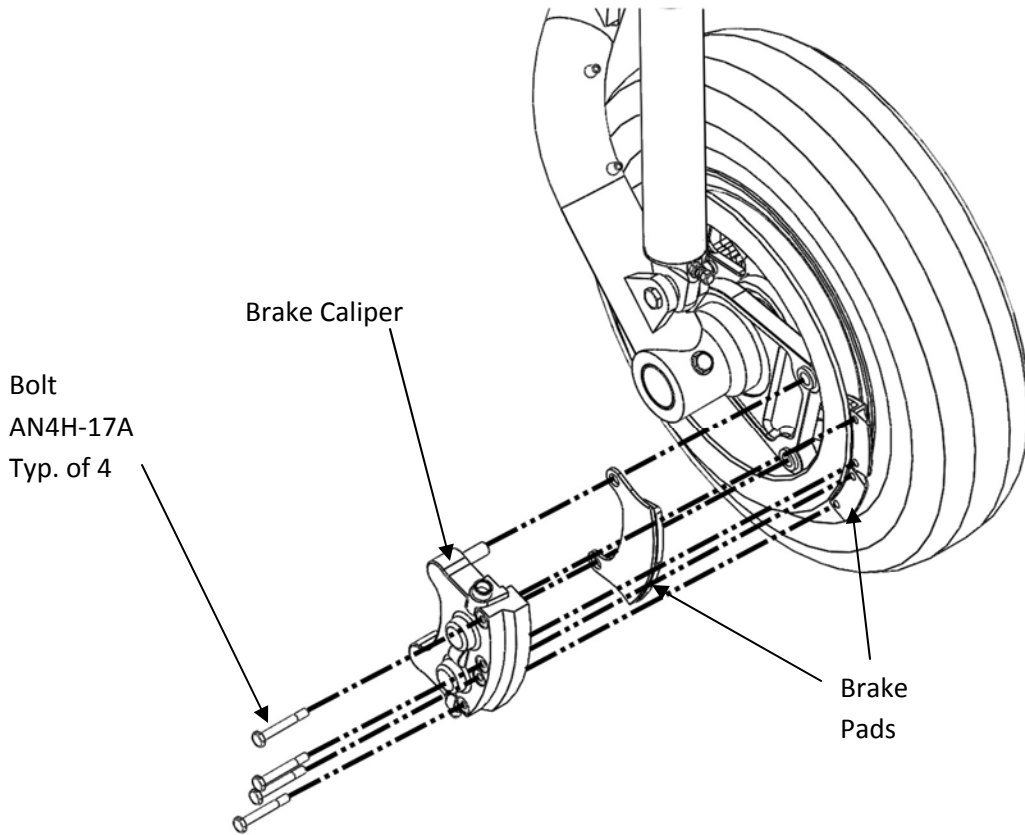

4. Remove the wheel cover.

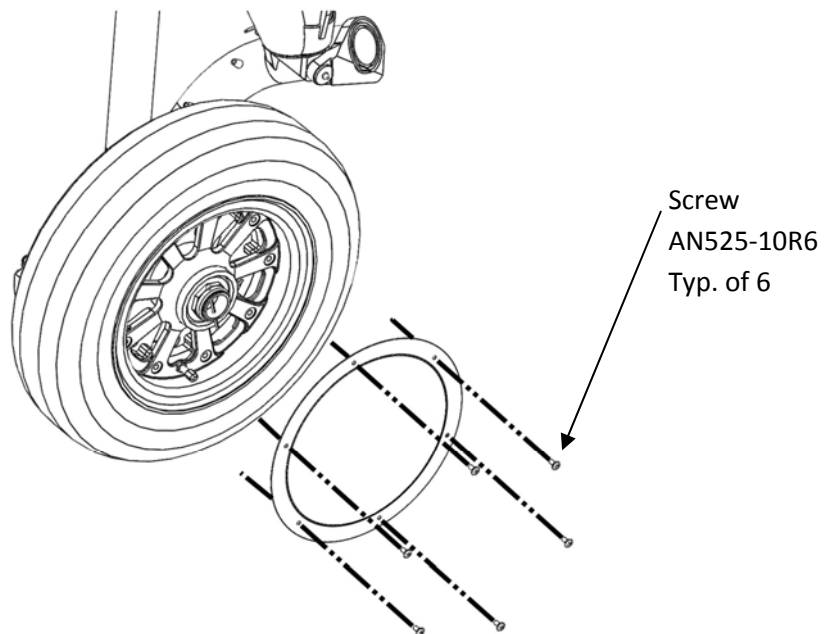

5. Remove the axle castle nut cotter pin.

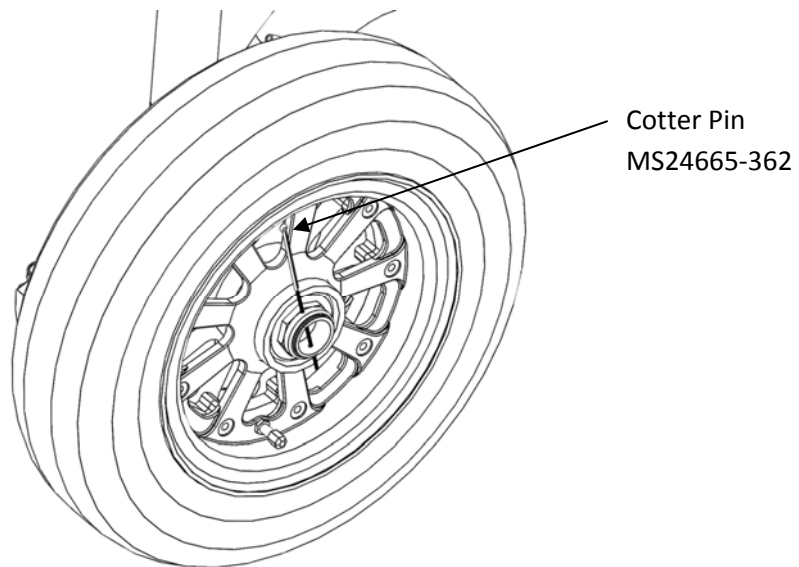

6. Remove the axle nut.

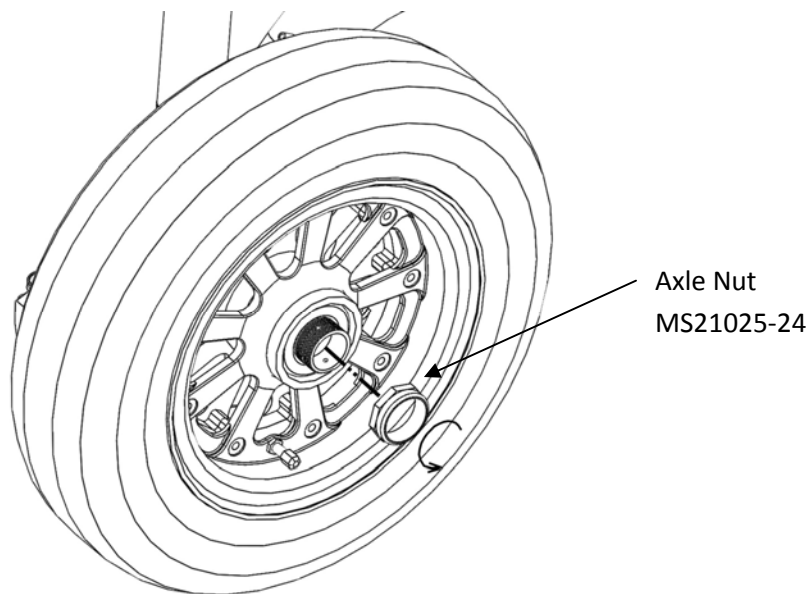

7. Remove the wheel.

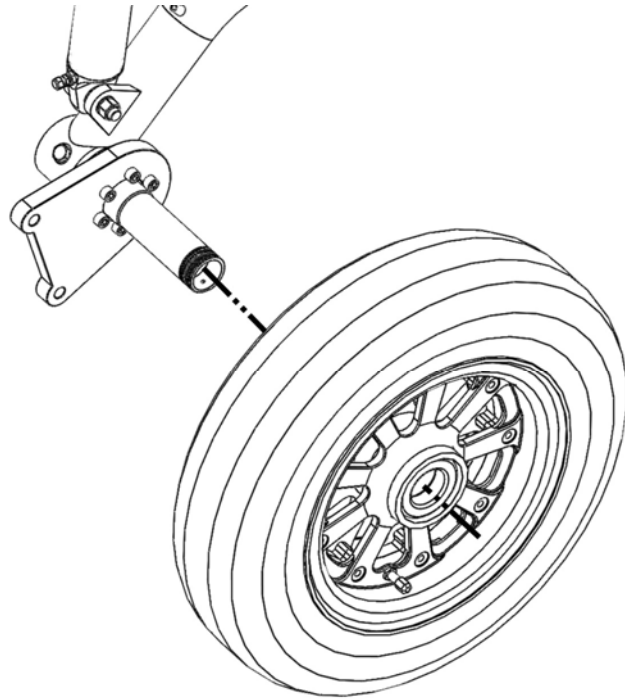

8. Remove the wheel spacer.

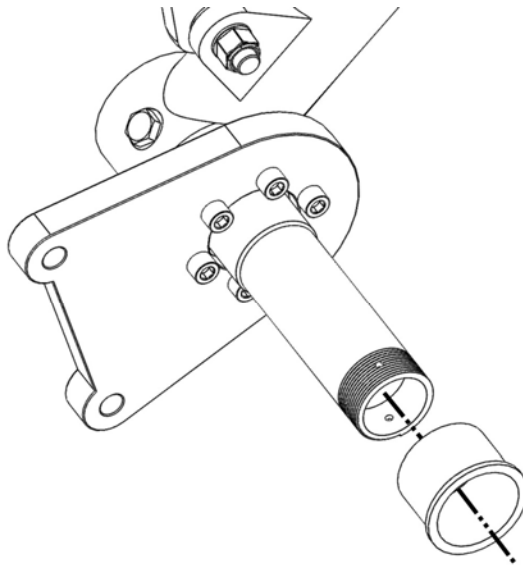

9. Drill new 0.136" diameter cotter pin holes 90° rotated from the existing holes and 1/8" outboard (toward the threaded end of the axle).

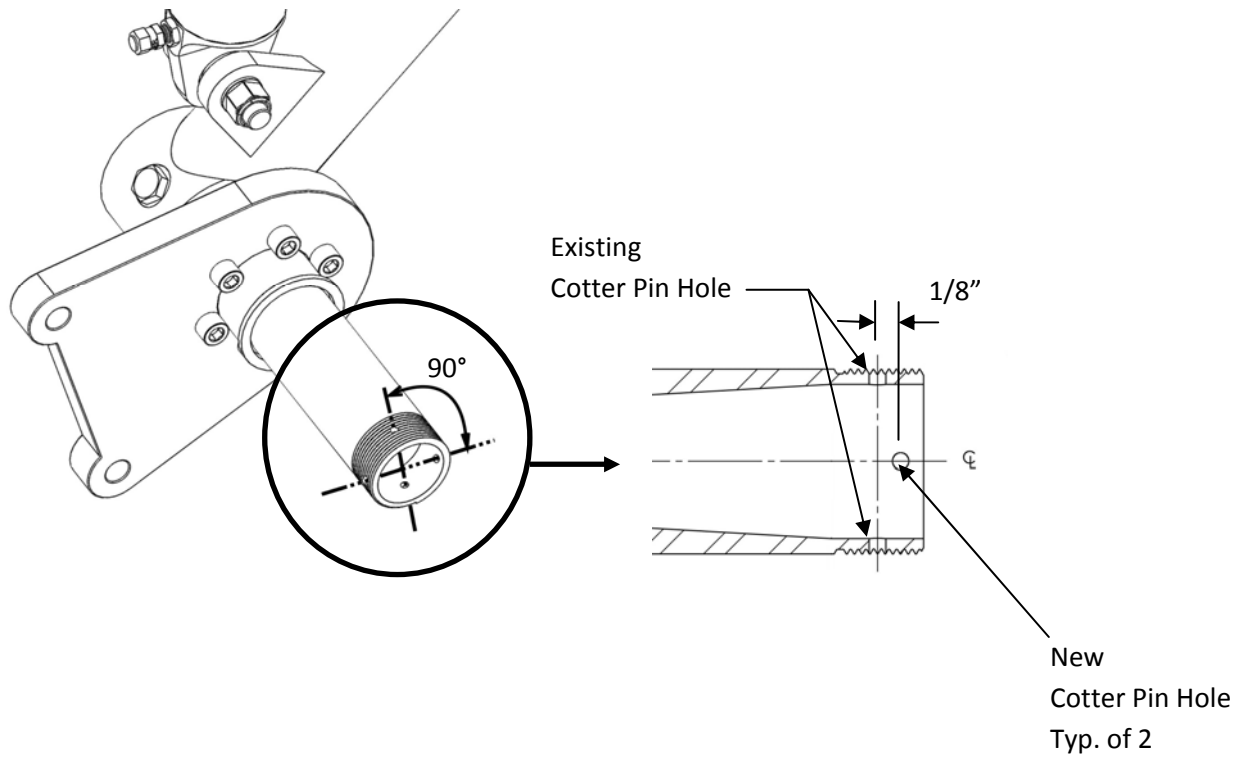

10. Remove 1/8" from the axle nut at the castellation.

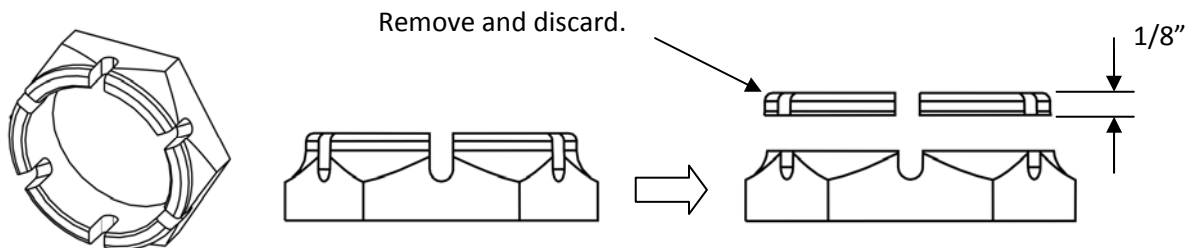

11. Slide the axle spacer onto the axle then through the torque plate until it rests against the trailing link.

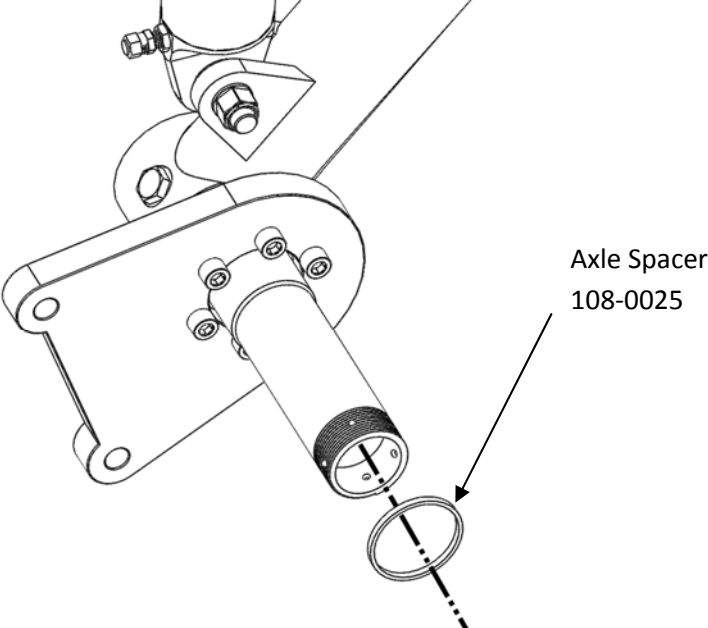

12. Install the wheel spacer.

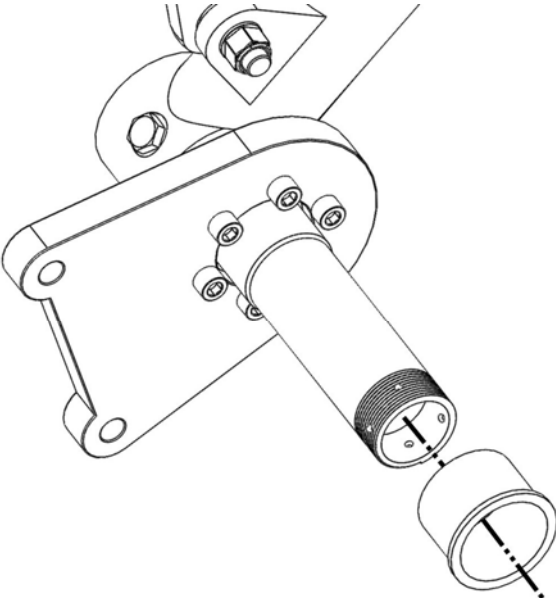

13. Install the wheel.

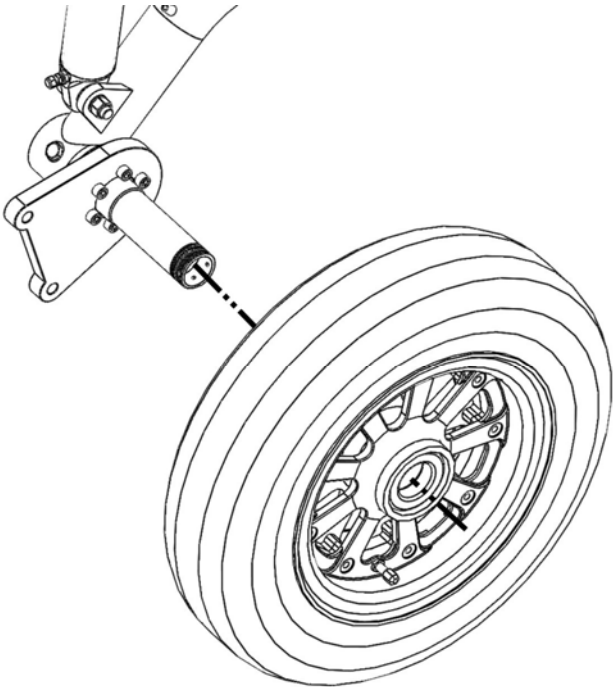

14. Install the modified axle nut.

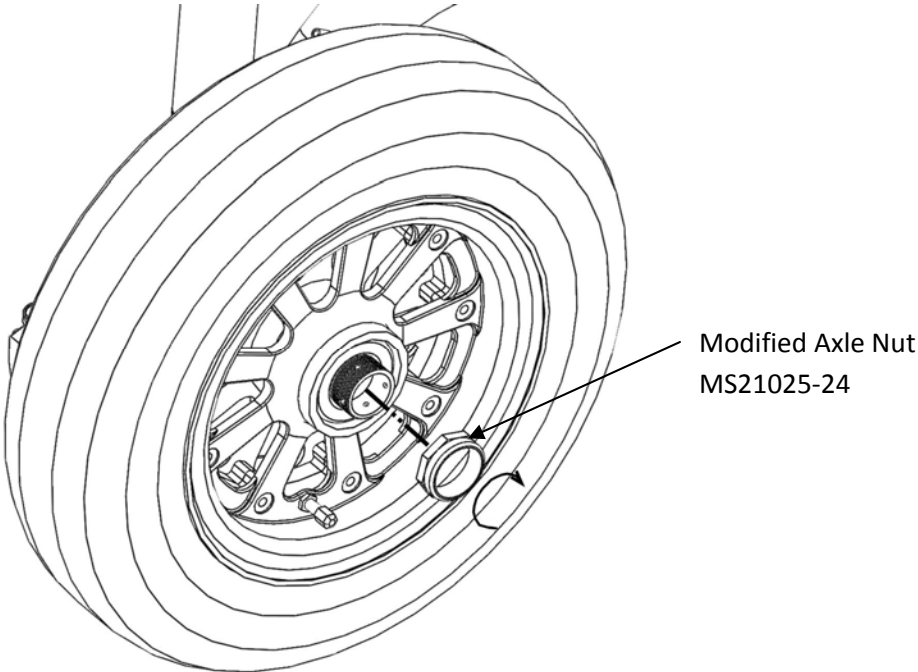

15. Tighten the nut until there is no play in the wheel bearings and then turn the nut further to the next available castellation.

16. Install a new axle castle nut cotter pin.

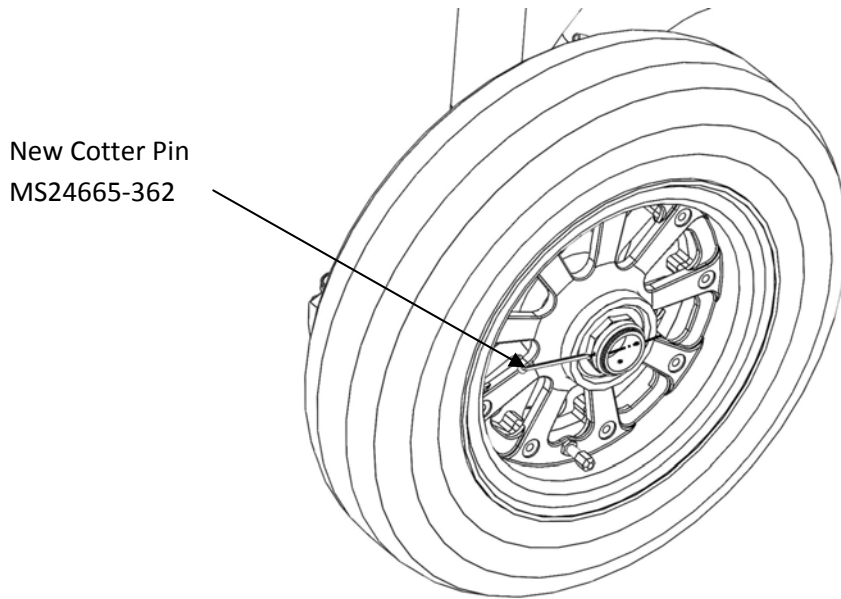

17. Install the brake caliper and brake pads.

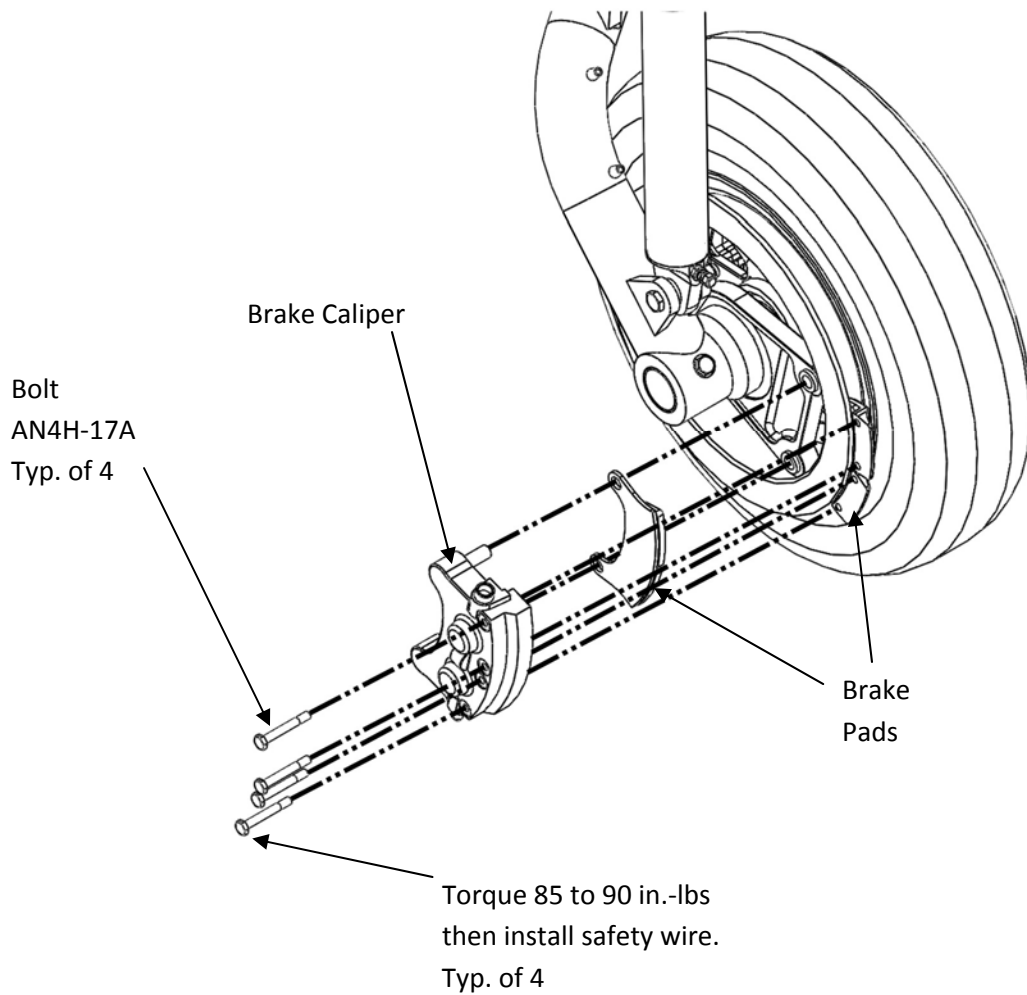



18. Install the wheel cover.

